

553.5041 Parking spaces for persons who have disabilities.--

(1) This section is not intended to expand or diminish the defenses available to a place of public accommodation under the Americans with Disabilities Act and the federal Americans with Disabilities Act Accessibility Guidelines, including, but not limited to, the readily achievable standard, and the standards applicable to alterations to places of public accommodation. Subject to the exceptions described in subsections (2), (4), (5), and (6), when the parking and loading zone requirements of the federal Americans with Disabilities Act Accessibility Guidelines (ADAAG), as adopted by reference in 28 C.F.R. part 36, subparts A and D, and Title II of Pub. L. No. 101-336, provide increased accessibility, those requirements are adopted and incorporated by reference as the law of this state.

(2) State agencies and political subdivisions having jurisdiction over street parking or publicly owned or operated parking facilities are not required to provide a greater right-of-way width than would otherwise be planned under regulations, guidelines, or practices normally applied to new development.

(3) If parking spaces are provided for self-parking by employees or visitors, or both, accessible spaces shall be provided in each such parking area. Such spaces shall be designed and marked for the exclusive use of those individuals who have a severe physical disability and have permanent or temporary mobility problems that substantially impair their ability to ambulate and who have been issued either a disabled parking permit under s. 316.1958 or s. 320.0848 or a license plate under s. 320.084, s. 320.0842, s. 320.0843, or s. 320.0845.

(4) The number of accessible parking spaces must comply with the parking requirements in ADAAG s. 4.1 and the following:

(a) There must be one accessible parking space in the immediate vicinity of a publicly owned or leased building that houses a governmental entity or a political subdivision, including, but not limited to, state office buildings and courthouses, if no parking for the public is provided on the premises of the building.

(b) There must be one accessible parking space for each 150 metered on-street parking spaces provided by state agencies and political subdivisions.

(c) The number of parking spaces for persons who have disabilities must be increased on the basis of demonstrated and documented need.

(5) Accessible perpendicular and diagonal accessible parking spaces and loading zones must be designed and located in conformance with the guidelines set forth in ADAAG ss. 4.1.2 and 4.6 and Appendix s. A4.6.3 "Universal Parking Design."

(a) All spaces must be located on an accessible route no less than 44 inches wide so that users will not be compelled to walk or wheel behind parked vehicles.

(b) Each space must be located on the shortest safely accessible route from the parking space to an accessible entrance. If there are multiple entrances or multiple retail stores, the parking spaces must be dispersed to provide parking at the nearest accessible entrance. If a theme park or an entertainment complex as defined in s. 509.013(9) provides parking in several lots or areas from which access to the theme park or entertainment complex is provided, a single lot or area may be designated for parking by persons who have disabilities, if the lot or area is located on the shortest safely accessible route to an accessible entrance to the theme park or entertainment complex or to transportation to such an accessible entrance.

(c)1. Each parking space must be no less than 12 feet wide. Parking access aisles must be no less than 5 feet wide and must be part of an accessible route to the building or facility entrance. In accordance with ADAAG s. 4.6.3, access aisles must be placed adjacent to accessible parking spaces; however, two accessible parking spaces may share a common access aisle. The access aisle must be striped diagonally to designate it as a no-parking zone.

2. The parking access aisles are reserved for the temporary exclusive use of persons who have disabled parking permits and who require extra space to deploy a mobility device, lift, or ramp in order to exit from or enter a vehicle. Parking is not allowed in an access aisle. Violators are subject to the same penalties that are imposed for illegally parking in parking spaces that are designated for persons who have disabilities. A vehicle may not be parked in an access aisle, even if the vehicle owner or passenger is disabled or owns a disabled parking permit.

3. Any provision of this subsection to the contrary notwithstanding, a theme park or an entertainment complex as defined in s. 509.013(9) in which are provided continuous attendant services for directing individuals to marked accessible parking spaces or designated lots for parking by persons who have disabilities, may, in lieu of the required parking space design, provide parking spaces that comply with ADAAG ss. 4.1 and 4.6.

(d) On-street parallel parking spaces must be located either at the beginning or end of a block or adjacent to alley entrances. Such spaces must be designed in conformance with the guidelines set forth in ADAAG ss. 4.6.2 through 4.6.5, exception: access aisles are not required. Curbs adjacent to such spaces must be of a height that will not interfere with the opening and closing of motor vehicle doors. This subsection does not relieve the owner of the responsibility to comply with the parking requirements of ADAAG ss. 4.1 and 4.6.

(e) Parallel parking spaces must be even with surface slopes, may match the grade of the adjacent travel lane, and must not exceed a cross slope of 1 to 50, where feasible.

(f) Curb ramps must be located outside of the disabled parking spaces and access aisles.

(g)1. The removal of architectural barriers from a parking facility in accordance with 28 C.F.R. s. 36.304 or with s. 553.508 must comply with this section unless compliance would cause the barrier removal not to be readily achievable. If compliance would cause the barrier removal not to be readily achievable, a facility may provide parking spaces at alternative locations for persons who have disabilities and provide appropriate signage directing persons who have disabilities to the alternative parking if readily achievable. The facility may not reduce the required number or dimensions of those spaces, nor may it unreasonably increase the length of the accessible route from a parking space to the facility. The removal of an architectural barrier must not create a significant risk to the health or safety of a person who has a disability or to that of others.

2. A facility that is making alterations under s. 553.507(2)(b) must comply with this section to the maximum extent feasible. If compliance with parking location requirements is not feasible, the facility may provide parking spaces at alternative locations for persons who have disabilities and provide appropriate signage directing persons who have a disability to alternative parking. The facility may not reduce the required number or dimensions of those spaces, nor may it unnecessarily increase the length of the accessible route from a parking space to the facility. The alteration must not create a significant risk to the health or safety of a person who has a disability or to that of others.

(6) Each such parking space must be prominently outlined with blue paint, and must be repainted when necessary, to be clearly distinguishable as a parking space designated for persons who have disabilities and must be posted with a permanent above-grade sign of a color and design approved by the Department of Transportation, which is placed on or at a distance of 84 inches above the ground to the bottom of the sign and which bears the international symbol of accessibility meeting the requirements of ADAAG s. 4.30.7 and the caption "PARKING BY DISABLED PERMIT ONLY." Such a sign erected after October 1, 1996, must indicate the penalty for illegal use of the space. Any provision of this section to the contrary notwithstanding, in a theme park or an entertainment complex as defined in s. 509.013(9) in which accessible parking is located in designated lots or areas, the signage indicating the lot as reserved for accessible parking may be located at the entrances to the lot in lieu of a sign at each parking place. This subsection does not relieve the owner of the responsibility of complying with the signage requirements of ADAAG s. 4.30.

History.--s. 66, ch. 2000-141.

TOTAL PARKING IN LOT	REQUIRED MINIMUM NUMBER OF ACCESSIBLE SPACES
Up to 25	1
26 to 50	2
51 to 75	3
76 to 100	4
101 to 150	5
151 to 200	6
201 to 300	7
301 to 400	8
401 to 500	9
501 to 1000	2 percent of total
over 1000	20 plus 1 for each 100 over 1000
A minimum of four parking spaces for disabled persons shall be provided at a physical restoration rehabilitation center or a hospital.	

15

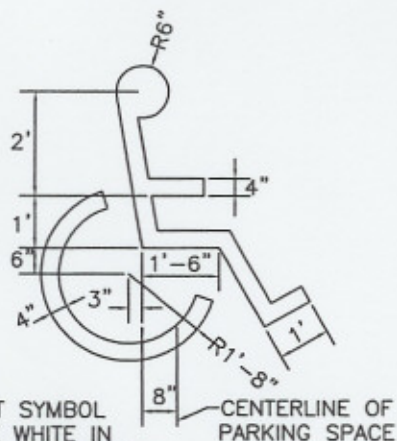

PAVEMENT SYMBOL SHALL BE WHITE IN COLOR AND INSTALLED PER FDOT INDEX NO. 17346

CENTERLINE OF PARKING SPACE

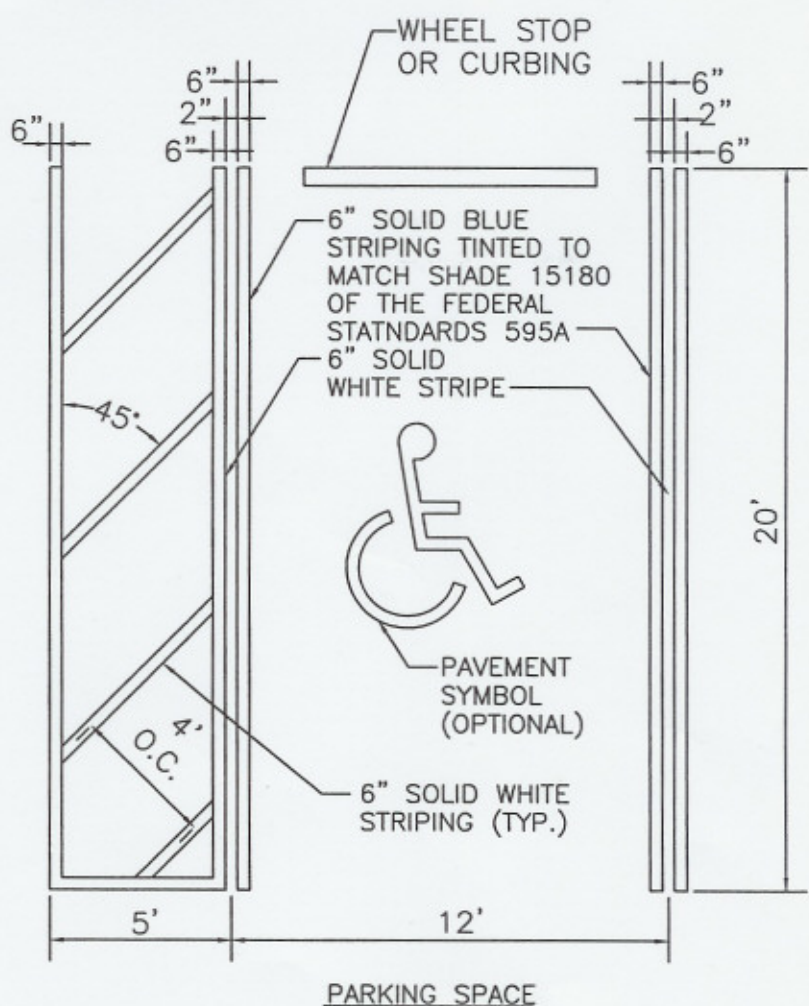

PARKING SPACE



FTP - 25
FDOT-17355

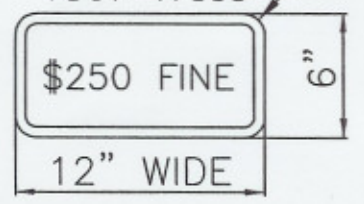

SUPPLEMENTAL PLATE WITH 1" BLUE OR BLACK LEGEND AND A 1/2" BLUE OR BLACK BORDER ON A WHITE BACKGROUND.

NOTES:

1. TOP PORTION OF FTP-25 SHALL HAVE A REFLECTIVE BLUE BACKGROUND WITH WHITE REFLECTIVE SYMBOL AND BORDER. BOTTOM PORTION SHALL HAVE A REFLECTIVE WHITE BACKGROUND WITH BLACK OPAQUE LEGEND AND BORDER.
2. PERPENDICULAR AND DIAGONAL HANDICAPPED PARKING STALLS WILL BE 12 FT. WIDE AND 20 FT. LONG WITH A 5 FT. WIDE ACCESS AISLE ADJACENT TO EACH STALL. THE 5 FT. WIDE ACCESS AISLE MAY BE SHARED BY TWO ADJACENT HANDICAPPED PARKING STALLS.
3. PARALLEL HANDICAPPED PARKING STALLS WILL BE 12 FT. WIDE AND 22 FT. LONG WITH A 5 FT. WIDE ACCESS AISLE ADJACENT TO EACH STALL.
4. ALL HANDICAPPED PARKING STALLS, 5 FT. WIDE ACCESS AISLES, HANDICAPPED RAMPS, AND ACCESSIBLE ROUTES MUST BE PAVED.
5. ALL HANDICAPPED RAMPS SHALL BE A MINIMUM OF 60" WIDE EXCLUSIVE OF THE FLARED SIDES WITH A MAXIMUM SLOPE OF 12:1 RAMPS TO BE CONSTRUCTED IN ACCORDANCE WITH FDOT INDEX NO. 304.
6. ONE FTP-25 OR FTP-26 SIGN WITH SUPPLEMENTAL SIGN IS REQUIRED FOR EACH HANDICAPPED PARKING STALL.
7. BOTTOM EDGE OF SIGN TO BE 7'-0" ABOVE PAVEMENT.
8. BLUE STRIPING SHALL BE TINTED TO MATCH SHADE 15180 OF THE FEDERAL STANDARDS 595C.